

## Data sheet

---

### RTX 110

#### PRODUCT DESCRIPTION

Electronic rotator for 90° product rotation.



#### MAIN FEATURES

---

- Cadences up to 85 ppm
- Four 90° blades for product positioning
- Resistive touch screen 7"
- Brushless motorized blades drive board with programmable degrees
- Closed loop brushless motorized input belt
- Closed loop brushless motor output belt
- Brushless motori and drive cards, speed up to 60 m/min
- Working temperature: from 0°C to +40°C
- Power supply: 230 Vac (Hz 50/60)
- Maximum power: 300 W
- Structure and carpentry in aluminum and stainless steel
- Height of belt from the ground: 850 +/- 50 mm
- Machine management via PLC

#### OPTIONS

---

- Resistive pc/panel 12" display, suitable for use with gloves and in the presence of water and condensation
- Input cadence conveyor belt
- Output conveyor belt for centering the product



## LAYOUT

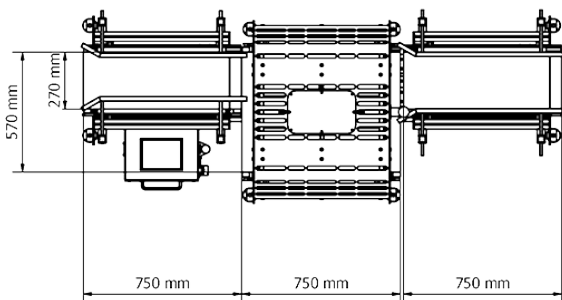
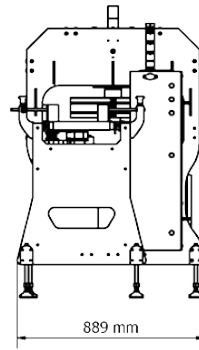
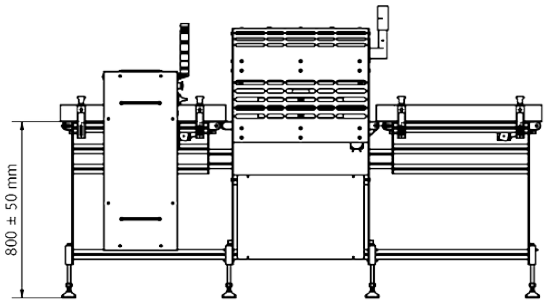



---

R.S. Bilance S.r.l.  
Via Rinaudo, 19, Valcorrente - 95032 Belpasso CT  
Tel. +39 095 3523283  
commerciale@rsbilance.com  
www.rsbilance.com