

## Data sheet

---

# FLASH APS

### PRODUCT DESCRIPTION

Labeling machine for label applications to the top of products.

Precise labeling, efficient speed and great reliability.



### MAIN FEATURES

---

- Cadences up to 100 ppm
- Working temperature: from 0°C to +40°C
- Power supply: 230 Vac (Hz 50/60)
- Structure and carpentry in aluminum and stainless steel
- Label dispensing speed up to 40 m/min
- Label width from 20 to 100 mm
- Label width from 20 to 620 mm
- Roll diameter 250 mm
- Multilingual 4.3" color control panel
- 100 program memory
- Pre T-ino-bobin control
- Paper break alarms
- External traffic light control
- Inkset printing control
- Label pre-dispensing control for two-step label application
- Machine management via PLC



## LAYOUT

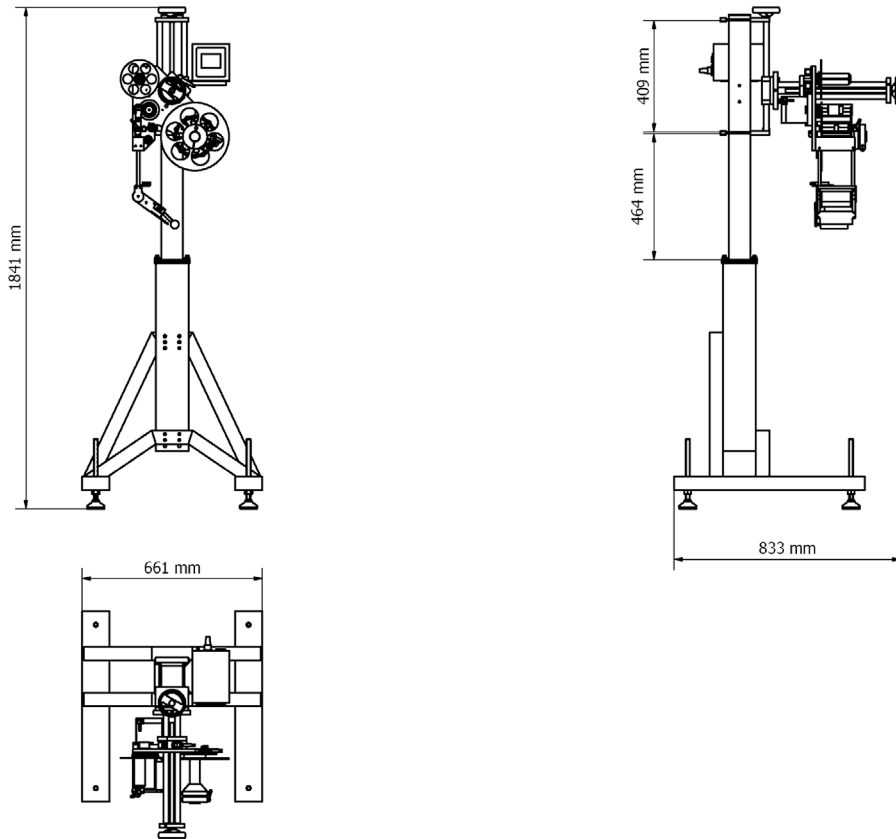



---

R.S. Bilance S.r.l.  
Via Rinaudo, 19, Valcorrente - 95032 Belpasso CT  
Tel. +39 095 3523283  
commerciale@rsbilance.com  
www.rsbilance.com