

Data sheet

CX DYNAMIC

PRODUCT DESCRIPTION

Checkweigher for small capacities.
It allows you to control predetermined weight products with statistical control that is fully configurable and can be integrated with external software. Approved (MID).



MAIN FEATURES

- Cadences up to 170 ppm
- Capacity: 3 kg - 1 g with motorised belts 90, 135, 180 mm width
- Capacity: 3 kg - 1 g / 6 kg - 2 g with motorised belts 225 mm width
- Capacity: 6 kg - 2 g with motorised belts 225, 270, 315 mm width
- 1 to 3 motorised closed-loop belts
- Brushless motors and drive boards, speed up to 70 m/min
- Working temperature: from 0°C to +40°C
- Power supply: 230 Vac (50/60 Hz)
- Maximum power: 1 belt 300 W, 2 belts 300 W, 3 belts 600 W
- 12" resistive PC/Panel display, suitable for use with gloves and in the presence of water/condensation
- Structure and carpentry in aluminium and stainless steel
- Height of belt from the ground: 850 +/- 50 mm
- Machine management via PLC
- LED light column for out of tolerance and alarms

OPTIONS

- 6000 divisions
- Capacity 15 kg - 5 g
- Network-based machine management software with RS server communication protocol
- 2D label presence and reading camera
- 2D QR Code reading camera
- External PROFIBUS interface, Profibus protocol with PCB.
- ETHERCAT communication protocol
- Piston ejector, arm and pneumatic blow
- Stainless steel and plastic collection basket
- Waste roller conveyor with collection basket
- Overflow photocell
- Slide diverter, 2 or 3 outputs
- Air diverter, 1, 2 or 3 outputs

Weight control program

Selectable functions

3 levels of login details with log-ins recorded on database

Conveyor cycle processing mode (no labelling) or fixed weight with weighing range set in the processing program (PLU)

Statistical control according to Law no. 690 of 25 October 1978 on the entire production batch and accompanying reports

Weighing range processing with automatic selection of the PLU associated with the range, up to three weighing ranges can be configured, thus enabling the simultaneous processing of three different PLUs

Integration of the METAL DETECTOR system and sharing of the processing report (total number of packages per item and batch, total number of contaminated packages per item and batch, etc.) and continuous monitoring of the status, with any faults displayed in real-time (e.g. NO COMMUNICATION, STORAGE FULL, ANTENNA FAILURE, etc.). Possible PLU selection of the referenced METAL DETECTOR directly in the checkweigher PLU

Integration of 2D barcode reading cameras, with the following possibilities:

- automatic selection of the PLU using the alphanumeric code read
- association of the operator code acquired via the QR Code with the weighed product in order to analyse the company processing
- with integrated Diverter system, possible automatic selection of up to three PLUs associated with the code/colour of the QR Code (respectively code 01/02/03 White/Yellow/Cyan) and activation of the associated diverter outlet, thus enabling the simultaneous processing of three different PLUs

Integration of the 2- or 3-way DIVERTER system to sort the production flow in downstream processing lines as required, with the following possibilities:

- association of the products being unloaded with one of the 2 or 3 diverter outlets (LEFT, CENTRE, RIGHT)
- with automatic operation and integrated camera, association of products with weight out of range with one of the 2 or 3 diverter outlets (LEFT, CENTRE, RIGHT), and consequently, the products within the threshold will be sorted into the other configured outlets
- with automatic operation and integrated camera, possible automatic selection of up to three PLUs associated with the code/colour of the QR Code (respectively code 01/02/03 White/Yellow/Cyan) and activation of the diverter outlet for products weighing within the threshold, thus enabling the simultaneous processing of three different PLUs
- with manual operation and three-way diverter, association of one diverter outlet with products weighing below the threshold, one outlet with products weighing above the threshold and the last outlet with products weighing within the threshold

Possible export to the desired location (local, network or USB port) of the master data (PLU database), Weighing Log database and Totals database

Remote database management through the exchange of csv files in shared folders, with the option of importing the PLU master data, configuring the diverter and exporting the weighing performed

Remote machine management via socket (IP address and port) with possible status request, PLU selection, start/stop and weight reception in real-time

Multilingual selection

Network-based machine management software with RS server communication protocol (optional)

Production data analysis software (optional)

PLU

PLU number: 9999

Each PLU is made up of 18 fields comprising machine parameters and production information:

- Alphanumeric primary key of max. length [10], unique PLU ID code
- 1 text field for the description of the machine PLU, max length [500]
- 2 fields for enabling and referencing (alphanumeric code [12]) the metal detector PLU
- 2 fields for automatically setting a tare value in [kg] and the processing batch
- 2 fields (Target [g] and Pack_Length [cm]) for setting the dynamic speed of the machine
- 2 fields (Speed and AUX_Speed [m/min]) for setting the static and auxiliary speed
- 2 fields (Threshold_Min and Threshold_Max [kg]) for setting the weighing range
- 1 field (Weighted) for enabling or disabling the conveyor cycle processing mode
- 3 fields for enabling and setting the ejection parameters (delay and time)
- 2 fields for enabling the alarm and setting the max number of ejections

Totals

Totals per PLU

I/O section

1 USB 2.0
1 Ethernet
2 Electrical signals (potential-free contacts)

Diagnostics

Continuous monitoring of the status of the machine and all integrated systems (consent from downstream, motor failure, encumbrances on the belts and all errors resulting from the integrated systems)



LAYOUT

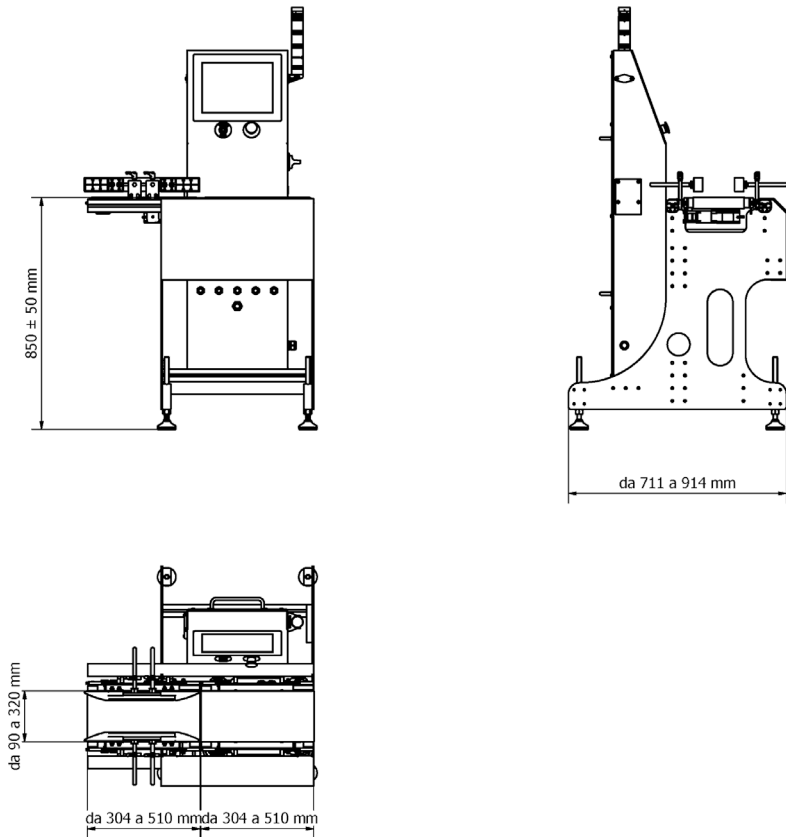

DIMENSIONS useful belt (mm)

	CADENZER	WEIGHING	LABELLING
SERIES 90	-	90x400	-
	90x400	90x400	-
	-	90x400	90x570
	90x400	90x400	90x570
SERIES 135	-	135x400	-
	135x400	135x400	-
	-	135x400	135x570/750
	135x400	135x400	135x570/750
	-	135x510	-
	135x510	135x510	-
	-	135x510	135x570/750
	135x510	135x510	135x570/750
SERIES 180	-	180x400	-
	180x400	180x400	-
	-	180x400	180x570/750
	180x400	180x400	180x570/750
	-	180x510	-
	180x510	180x510	-
	-	180x510	180x570/750
	180x510	180x510	180x570/750
SERIES 225	-	225x510	-
	225x510	225x510	-
	-	225x510	225x570/750
	225x510	225x510	225x570/750
SERIES 270	-	270x510	-
	270x510	270x510	-
	-	270x510	270x570/750
	270x510	270x510	270x570/750
SERIES 315	-	315x510	-
	315x510	315x510	-
	-	315x510	315x570/750
	315x510	315x510	315x570/750

